

FONTANA (LED)

Max Ingrand, 1954

An exquisite object, almost entirely in white blown glass, composed of a round element that tapers slightly upward, surmounted by a truncated cone: the classic form of the abat-jour lamp that defined an era in lighting. The peculiarity of Fontana is its multiple light sources: both the base and the lampshade contain one or more. The larger version also allows indirect lighting, thanks to an additional source that projects a beam of indirect light upwards. The differentiated light sources make it possible to satisfy different lighting needs: from a soft, relaxing glow to a sharp beam for reading to suggestive ambient light. The soft and perfectly proportioned forms, the purity of the design and the milky opalescent finish combine to make it a timeless piece, perfect in every setting, whether turned on or off. Now available with Led light sources.



RELATED PRODUCTS

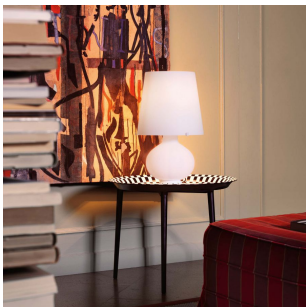

FONTANA

Table Lamp

TECHNICAL SHEET

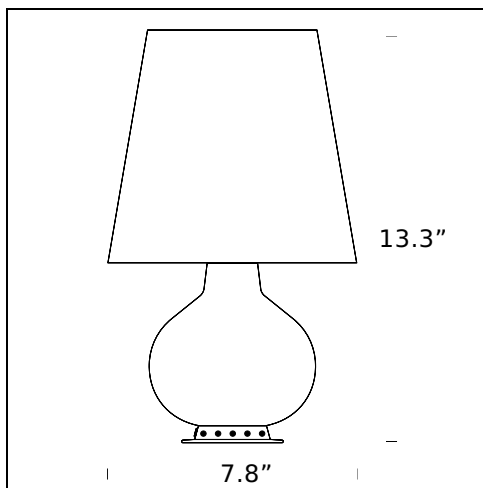

MODEL NAME: Fontana (Led)

CODE: 1853/0/LED

DIMENSION: \varnothing 7.8" \times 13.3"

MATERIALS: Glass

LIGHTING SOURCE: 6,5W + 4W LED (2700 K, CRI>80, 1300 Lm)

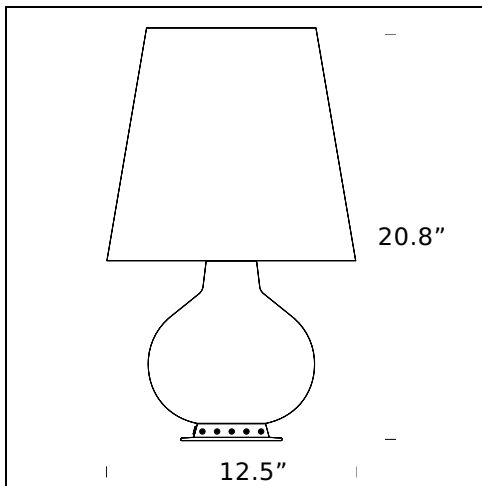

MODEL NAME: Fontana (Led)

CODE: 1853/LED

DIMENSION: \varnothing 12.5" \times 20.8"

MATERIALS: Glass

LIGHTING SOURCE: 9W + 5,5W LED (2700 K, CRI>80, 1800 Lm)

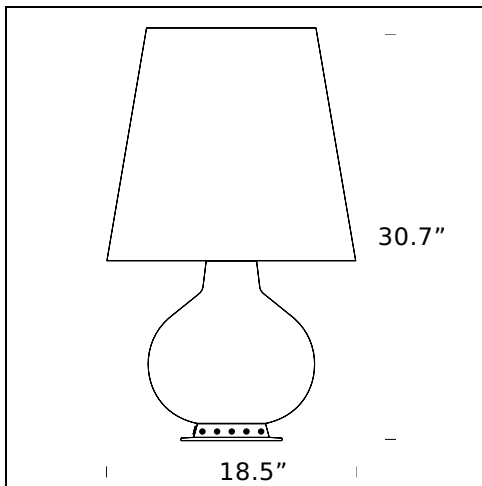

MODEL NAME: Fontana (Led)

CODE: 1853/1/LED

DIMENSION: \varnothing 18.5" x 30.7"

MATERIALS: Glass

LIGHTING SOURCE: 9W + 4x4W + 5,5W LED (2700 K, CRI>80, 3600 Lm)

Subject to technical modifications and modifications to content