

UOVO (LED)

Ben Swildens, 1972

The egg: a natural form and timeless symbol of perfection, in which symmetry and asymmetry harmoniously coexist. Uovo is the subject of a sketch recovered in 1972 in the historical archives of FontanaArte, in which the 'shell' of the egg contained a light source: an ironic idea that still works today. As in nature, the shell of the Uovo lamp is the embodiment of absolute lightness, an elegant form in white satin blown glass that gives off a warm, uniform light. Available in three sizes, it has all the versatility of a collection designed for multiple uses: from the small version which serves as a tiny utility lamp to the large version, a veritable light sculpture, protagonist of any space. Now available with Led light source.



RELATED PRODUCTS



UOVO

Table Lamp

TECHNICAL SHEET

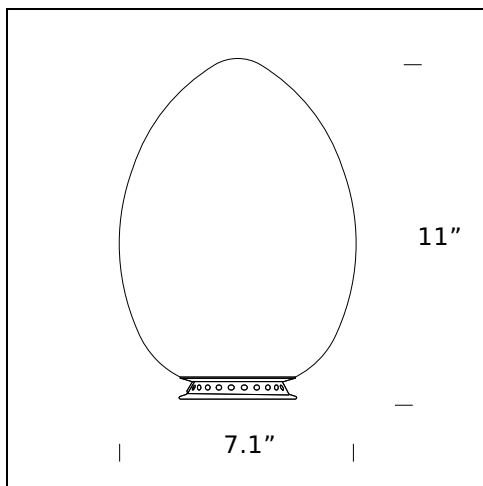

MODEL NAME: Uovo (Led)

CODE: 2646/0/LED

DIMENSION: \varnothing 7.1" \times 11.0"

MATERIALS: Glass

LIGHTING SOURCE: 6,5W LED (2700 K, CRI >80, 680 Lm)

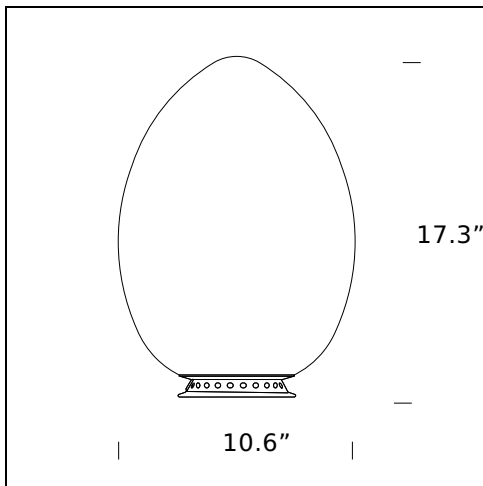

MODEL NAME: Uovo (Led)

CODE: 2646/1 /LED

DIMENSION: \varnothing 10.6" \times 17.3"

MATERIALS: Glass

LIGHTING SOURCE: 9W LED (2700 K, CRI >80, 950 Lm)

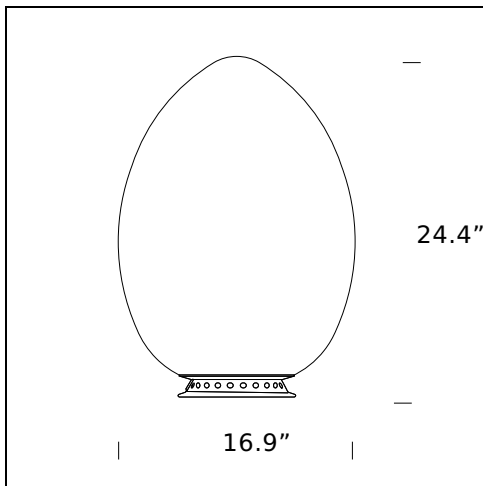

MODEL NAME: Uovo (Led)

CODE: 2646 /LED

DIMENSION: \varnothing 16.9" \times 24.4"

MATERIALS: Glass

LIGHTING SOURCE: 11W LED (2700 K, CRI >80, 950 Lm)

Subject to technical modifications and modifications to content